

IOT Enabled Smart Object Sorting Machine with Real Time Monitoring

¹Kamalavati Gudise, ²Pranjali Kadam, ³Sahil Kale, ⁴Aditi Khandare, ⁵Prof. Sangita R. Nandurkar

^{1,2,3,4}Under Graduate Student, A.C Patil College of Engineering, Kharghar, University of Mumbai, Navi Mumbai, Maharashtra, India

⁵Assistant Professor, A.C Patil College of Engineering, Kharghar, University of Mumbai, Navi Mumbai, Maharashtra, India
Author for Correspondence: ³Skale@acpce.ac.in, ⁵srnandurkar@acpce.ac.in

Abstract - The Smart Object Sorting Machine is an IoT-enabled automated system designed to classify objects based on colour and magnetic properties. Objects placed on a conveyor belt are detected using an IR sensor, triggering belt movement. A colour sensor identifies the object's colour, followed by a magnetic sensor to check magnetism. Based on the readings, a servo motor aligns the correct container for object deposition. All data, including object type, sorting time, and status, is logged and accessible remotely via mobile or laptop. The system integrates ESP32, sensors, DC motors, servos, and IoT technologies to ensure efficient, accurate, and real-time object sorting.[1]

Keywords: Smart sorting, object classification, IoT automation, ESP32, colour sensor, magnetic sensor, servo motor, DC motor, IR module, conveyor belt, solenoid, LED indicators, buzzer alert, voltage regulator, MOSFET motor control.

I. INTRODUCTION

The Smart Object Sorting Machine project focuses on automating object classification using sensors, motors, and IOT technology. Traditional sorting methods, reliant on manual labour, are Inefficient and prone to mistakes, particularly in large-scale industrial environments. This project leverages modern electronics to streamline sorting by detecting object arrival, colour, and magnetic properties, and directing them to appropriate containers. [1]

The approach emphasizes precision, speed, and real-time monitoring, allowing operators to track sorting operations remotely. The integration of ESP32 as the central controller ensures seamless communication between sensors, motors, and IoT platforms. This project is relevant to industries, recycling plants, and laboratories seeking to optimize workflows, reduce human dependency, and improve productivity. By combining automation with IoT the project demonstrates how smart systems can enhance operational efficiency, ensure accurate sorting, and provide meaningful data insights. [2]

It reflects the ongoing shift towards technology mitigates human limitations, reduces labour costs, and ensures timely processing of large quantities of objects. Ultimately, intelligent industrial processes, where this project exemplifies the practical application of automation and IoT for real-world industrial challenges, emphasizing efficiency, adaptability, and data-driven control.

II. PROBLEM STATEMENT

Industries and recycling units face challenges in manually sorting objects based on colour and magnetic properties. Manual sorting is time-consuming, error-prone, and inefficient for large-scale operations. Incorrect segregation leads to production delays, contamination, and increased labour costs. An automated sorting system is necessary to reduce human intervention, improve accuracy, and enhance productivity. By addressing these challenges, industries can achieve faster sorting, higher precision, and real-time monitoring of object classification. [5]

III. OBJECTIVE

The primary objective is to automate the sorting of objects efficiently based on color and magnetic properties. Secondary objectives include enabling real-time monitoring and logging of sorting operations via IoT, reducing manual labor, minimizing human error, and improving industrial productivity. The project also aims to integrate multiple sensors, motors, and IoT modules for synchronized operation. Another objective is to design a system that is scalable and adaptable for various industrial and recycling applications. Overall, the system ensures faster, accurate, and reliable sorting, providing a practical solution to modern automation challenges in object classification. [8]

IV. METHODOLOGY

The project was developed through a structured workflow encompassing hardware, software, and testing phases: The Smart Object Sorting Machine was designed with a phased methodology to ensure accurate and efficient sorting. Initially,

hardware components were selected based on compatibility, reliability, and performance, including ESP32, sensors, motors, and IoT modules. Circuit design integrated power management and motor control for safe operation. Software was implemented for sensor reading, motor control, servo alignment, and IoT data logging. Multiple test cycles validated system performance under different object types, sizes, and environmental conditions. Feedback was used to calibrate sensors, adjust timing, and improve servo alignment. This structured approach ensured a robust, scalable, and efficient sorting system. [3]

V. REVIEW OF LITERATURE

The proposed system works on a microcontroller which is widely used in the industries. The system will work when any coloured object is placed on the conveyor belt. The object can be coloured Red, Blue, Green or a mixture of any of these colours. A colour sensor is attached on the side of conveyor belt for detection of the object. The colour sensor will read the colour values in terms of RGB percentage of the object colour and compare it with a predetermined value threshold already programmed using the microcontroller. If the colour sensor will find the colour to be above the threshold it will instruct the microcontroller to activate the piston right next to the colour sensor. The piston will now push the object into a bucket right in front of it.

If the colour sensor reads a different value, then the set threshold it will just pass it forward where another piston will sort the product in another bucket. The system will become more complex if we want to increase the number of objects sorted based on different colours. Microcontroller has been used to control the various operations. It is a very useful in a wide variety of industries with the help of a microcontroller. [6]

System block diagram of Colour Sorting Machine

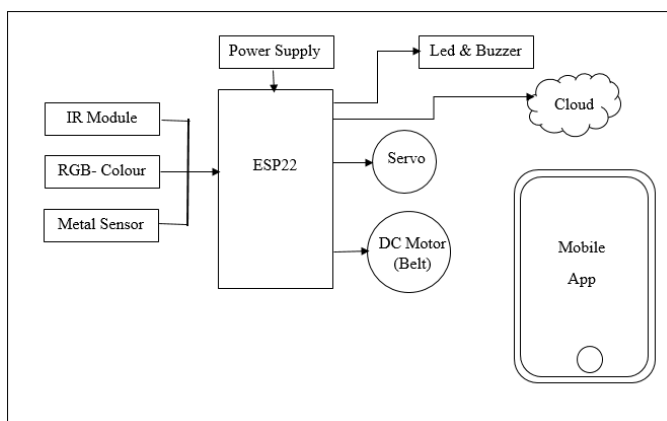

Figure 1: Block Diagram of Smart Object Sorting Machine

A smart object sorting machine's block diagram typically includes a sensor/vision system to identify objects, a controller (like a microcontroller) to process data, and an actuator (such as a robotic arm or air jet) to physically sort them. The process starts with objects on a conveyor, which are captured by a sensor. The sensor's data is sent to the controller, which analyzes it and sends a command to the actuator to move the object to its designated bin. A power supply unit provides power to all components.

Matlab Simulink Model & obtained Result

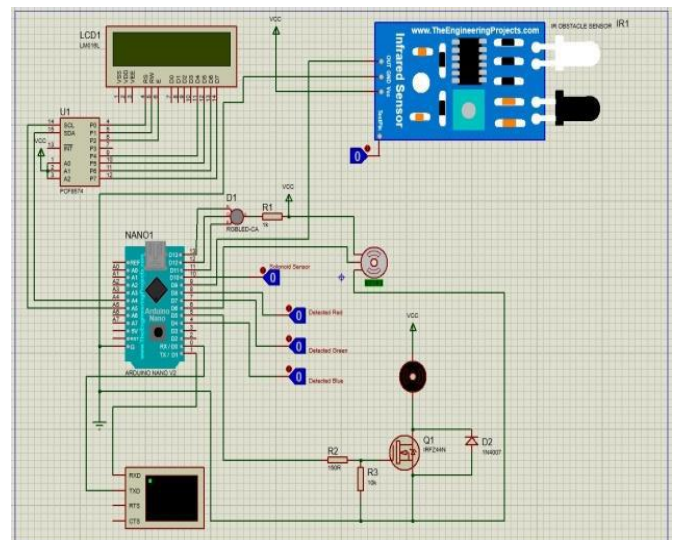

Figure 2: Simulink model of colour based sorting machine

Objects placed on the conveyor belt are detected by the IR sensor, activating belt movement. The color sensor identifies the object's color, and the magnetic sensor determines magnetism. Based on these readings, the ESP32 controls a servo motor to align the correct container in front of the belt. The conveyor resumes, allowing the object to drop into the appropriate slot. Each sorting event, including object type, detection time, and container assignment, is logged. Data is transmitted via IoT to mobile or laptop interfaces for real-time monitoring. The system ensures accurate, automated sorting, reduces human intervention, and enables scalable industrial operations. [4]

Click on the IR sensor then it sense the object and conveyer belt will start rotate.

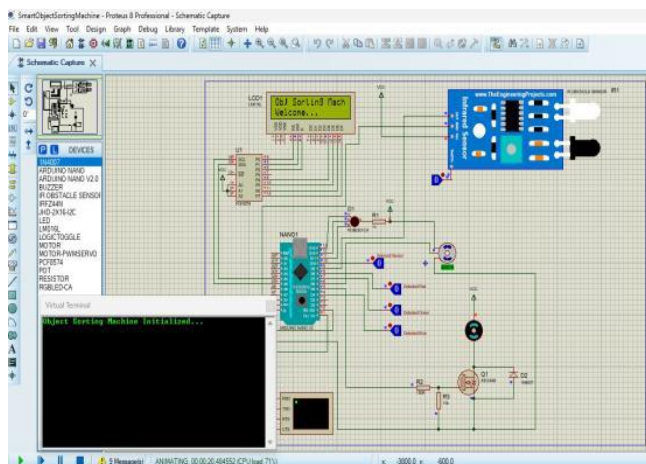

Figure 3: Obtained result of sorting machine initialization

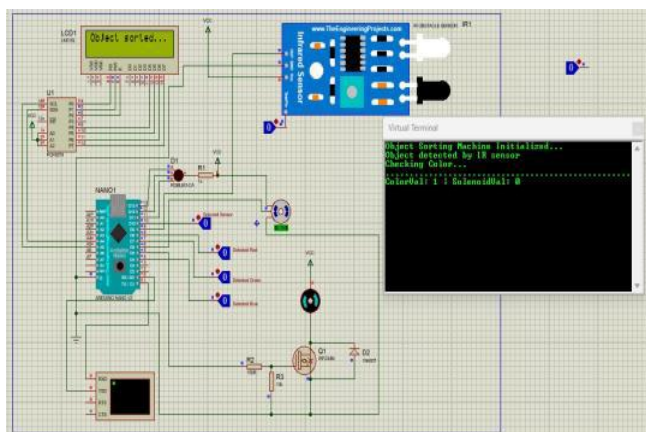

Figure 4: Obtained result of sorting colour based objects

When sensor sense the object colour is green then it will show on LCD display and virtual terminal colour green is represent as no.2.

VI. CONCLUSION

The Smart Object Sorting Machine successfully automates object classification with high accuracy, combining colour and magnetic detection with IoT-enabled monitoring. The system reduces manual labour, improves operational efficiency, and ensures safe handling. Its modular and scalable design allows adaptation across industrial, recycling, and laboratory environments. Real-time data logging and remote accessibility demonstrate the practical benefits of integrating automation and IoT. Overall, the project showcases a reliable, efficient, and sustainable approach to modern object sorting challenges. [7]

REFERENCES

[1] Krishna Jadhav, Gaurav Chaudhari, Abhishek Jadhav, Shubham Kondeka, Prof. Nagre V L, "IOT Colour Based Product Sorting Machine". Vol 6, Issue 1, Feb 2019.

[2] Himanshu Patel, Selin Macwan, Hardik Modi, "IOT Colour Based Object Sorting Machine". Vol 13, Number 10, 2018.

[3] Ch. Shravani, G. Indira, V. Appalaraju, "Arduino Based Colour Sorting Machine Using TCS3200 Colour Sensor". Vol 8, Issue 6S4, April 2019.

[4] Akriti Kaushik, Aastha Sharma (September 2013), "RgB Color Sensing Technique", *International Journal Of Advance Research In Science And Engineering, IJARSE*, Volume 2, Issue 9, ISSN-2319-8354(E), Available from <http://www.ijarse.com>

[5] Tushar G Gaikar, Soham N Zadokar, Rajendra S Bhandari, Sagar S Patil, "Object Sorting using Color Sensor and Arduino", *International Journal on Recent and Innovation Trends in Computing and Communication*, Volume 4, Issue 4, pp. 483–486, ISSN:2321-8169.

[6] Mingwei Liu, "EEL5666 Intelligent Machine Design Lab" Available from https://mil.ufl.edu/5666/papers/IMDL_Report_Spring_11/Final%20Reports/Mingwei_Liu/Mingwei_Liu.pdf

[7] Abhishek Kondhare, Garima Singh, Neha Hiralkar, MS Vanjale (2014), "Color and Shape Based Object Sorting", *International Journal of Scientific Research And Education*, Volume 2, Issue 3, pp. 553–562, SS (e):2321-7545.

[8] M Anil Kumar, Dr. SAK Jilani, Mr. U Sreenivasulu, Mr. S Javeed Hussain (August 2015), "Automated Color Recognition System for Visually Challenged and Achromatopsia People using Arduino and Mobile App", *International Journal of Advanced Research in Electronics and Communication Engineering (IJARECE)*, Volume 4, Issue 8, ISSN: 2278–909X.

Citation of this Article:

Kamalavati Gudise, Pranjali Kadam, Sahil Kale, Aditi Khandare, & Prof. Sangita R. Nandurkar. (2026). IOT Enabled Smart Object Sorting Machine with Real Time Monitoring. *International Research Journal of Innovations in Engineering and Technology - IRJIET*, 10(3), 156-159. Article DOI <https://doi.org/10.47001/IRJIET/2026.103021>
