

Real Time Transformer Monitoring System

¹Nikhil Jadhav, ²Pramod Bhatane, ³Rohan Sarde, ⁴Soham Waghmare, ⁵Narendra Neginhal

^{1,2,3,4}Student, Electrical Engineering, Zeal College of Engineering and Research, Pune, Maharashtra, India

⁵Professor, Electrical Engineering, Zeal College of Engineering and Research, Pune, Maharashtra, India

Abstract - Power transformers are essential components of power distribution systems and require continuous monitoring to ensure reliable operation and prevent unexpected failures. This paper presents a Real Time Transformer Monitoring System using IoT for continuous monitoring of transformer parameters such as voltage, current, temperature, humidity, and oil level. The system uses an Arduino UNO SMD integrated with sensors to collect real-time data and transmit it through an IoT platform for remote access and analysis. An LCD module displays live readings locally, while a buzzer and relay provide automatic fault indication and protection during abnormal conditions. The proposed system reduces manual inspection, improves operational safety, supports predictive maintenance, and enhances transformer efficiency and reliability through intelligent monitoring and automated control.

Keywords: Internet of Things (IoT), Transformer Monitoring, Arduino UNO, Voltage Sensor, Current Sensor, Temperature Monitoring, Relay Protection, Remote Monitoring.

I. INTRODUCTION

Power transformers are among the most important and expensive components of electrical power systems, serving a crucial role in power generation, transmission, and distribution networks. Their primary function is to transfer electrical energy efficiently from one voltage level to another while maintaining system stability and minimizing energy losses. Since transformers operate continuously under different environmental and loading conditions, maintaining their performance and reliability is essential for uninterrupted power supply. Any unexpected transformer failure may result in power outages, equipment damage, increased operational costs, and reduced overall efficiency of the electrical network. Therefore, continuous monitoring and protection of transformers have become increasingly important in modern power management systems.

Traditionally, transformer condition monitoring has been performed through routine inspections and periodic maintenance schedules. Operators manually measure electrical and environmental parameters such as voltage, current, oil condition, and temperature to assess transformer health. Although these methods are widely used, they provide only

limited information and are unable to detect developing faults in real time. Critical issues such as overheating, overload conditions, insulation deterioration, oil leakage, and abnormal voltage variations may remain unnoticed until serious damage occurs. Such failures not only affect transformer performance but also lead to costly repairs and interruptions in electrical service.

With the advancement of embedded electronics, wireless communication, and smart technologies, the **Internet of Things (IoT)** has emerged as an effective solution for real-time monitoring applications. IoT enables devices equipped with sensors and communication modules to collect, process, and exchange data over internet platforms. This technology allows continuous monitoring of equipment conditions and supports remote access to system information from any location. In transformer applications, IoT-based monitoring enables operators to observe performance continuously, receive instant alerts, and perform timely maintenance actions to prevent major failures.

The proposed **Real Time Transformer Monitoring System using IoT** is developed to provide intelligent monitoring and automatic protection of transformer operating conditions. The system uses **Arduino UNO SMD** as the main control unit responsible for collecting and processing data from various sensors connected to the transformer setup. Multiple sensing modules are incorporated to monitor essential transformer parameters in real time.

The system includes a **ZMPT voltage sensor** to continuously measure transformer voltage and identify abnormal voltage conditions. A **current sensor** is integrated to monitor load current and detect overload situations. To evaluate environmental conditions affecting transformer performance, a **DHT11 sensor** is used to measure temperature and humidity. Since transformer oil is important for insulation and cooling, a **level sensor** is incorporated to monitor oil level and detect possible leakage conditions. Additionally, a potentiometer is included for calibration and testing purposes during implementation.

All measured data are processed by the Arduino controller and displayed locally through an LCD display for direct observation. The monitoring information is also transmitted to an IoT platform where users can access real-

time data through mobile devices or web-based interfaces. This remote monitoring capability reduces the need for manual inspection and enables faster decision-making for maintenance activities.

To enhance system safety, the proposed design incorporates an automatic protection mechanism. Whenever any monitored parameter exceeds predefined safe limits—such as excessive temperature, abnormal current, voltage fluctuations, or low oil level—the system activates a buzzer alarm and operates a relay module to disconnect the transformer load. This immediate response helps prevent severe equipment damage and increases transformer operational life.

The implementation of IoT-based transformer monitoring provides several advantages including continuous supervision, reduced maintenance effort, improved reliability, lower operating costs, and early fault identification. The collected data can also support predictive maintenance techniques by identifying performance trends before failures occur. Therefore, the proposed system offers a smart, economical, and efficient solution for transformer health monitoring and contributes to the development of intelligent and automated power distribution systems.

II. LITERATURE REVIEW

Recent developments in transformer monitoring focus on integrating **IoT, real-time sensing, cloud connectivity, fault detection, and predictive maintenance** to improve transformer reliability and reduce maintenance cost. The following literature review summarizes recent research papers related to **Real Time Transformer Monitoring System using IoT**.

[1] **Msane M.R., Thango B., and Ogudo K. (2024)** presented a systematic literature review on IoT-based transformer condition monitoring. The study reviewed transformer monitoring frameworks developed between 2014–2024 and reported that Arduino-based architectures and IoT communication platforms are widely adopted for transformer fault detection and health assessment. The review highlighted predictive maintenance and remote monitoring as major research trends.

[2] **Transformer Monitoring with Electromagnetic Energy Transmission and Wireless Sensing (2024)** proposed a wireless transformer monitoring approach using electromagnetic energy transmission and sensing devices. The study aimed to improve reliability and reduce false alarms by enabling continuous transformer supervision and remote diagnosis.

[3] **Ragavan M. et al. (2023)** reviewed recent advancements in transformer health monitoring using IoT technologies. The paper emphasized the use of sensors, communication protocols, cloud platforms, and decision-making algorithms to support efficient transformer condition monitoring and predictive maintenance.

[4] **Rehman S.U. et al. (2023)** developed an IoT-enabled distribution transformer monitoring and protection system that continuously measures operating conditions and provides automatic protection during abnormal events. The proposed approach demonstrated improved monitoring efficiency and reduced maintenance requirements.

[5] **Dash S. et al. (2023)** proposed a smart transformer health monitoring and control system for substations using IoT technology. The system monitored critical operating parameters and supported fault detection and automated operational response for transformer protection.

[6] **Equbal M.D. et al. (2022)** introduced an IoT-based transformer fault classification method using electronic nose (E-Nose) sensing and ANFIS techniques. Their work improved identification of transformer incipient faults and demonstrated intelligent fault analysis capability.

[7] **Ramesh J. et al. (2022)** proposed a machine learning-based smart distribution transformer monitoring and management system. Their model combined intelligent load monitoring with predictive analysis to enhance transformer performance and support smart grid applications.

[8] **UPIoT Based Power Monitoring of Transformer (2022)** developed a cloud-connected transformer monitoring framework for measuring voltage, current, and temperature. The collected information was uploaded for remote supervision and early fault detection.

[9] **Deepti S. Shastrimath et al. (2022)** presented an IoT-based transformer condition monitoring system focused on continuous monitoring of transformer health parameters and instant fault notification to authorized users.

[10] **Mishra N. et al. (2022)** surveyed IoT-based transformer health monitoring approaches and concluded that integrating sensors with cloud communication significantly improves transformer protection and operational reliability.

From the reviewed literature, it is observed that many existing systems monitor only selected parameters such as temperature, voltage, or current. Limited studies provide an integrated solution combining **voltage monitoring, current sensing, temperature and humidity monitoring, oil level detection, IoT-based remote access, local LCD display,**

alert generation, and automatic relay protection in a single low-cost platform. Therefore, the proposed **Real Time Transformer Monitoring System using IoT** aims to provide comprehensive real-time monitoring and intelligent transformer protection.

III. RESEARCH GAP

From the reviewed literature, it is observed that most existing transformer monitoring systems concentrate mainly on monitoring limited parameters such as **voltage, current, or temperature** and do not provide complete transformer health assessment. Several systems lack integration of important parameters like **humidity and transformer oil level**, which are essential for maintaining transformer efficiency and preventing failures.

Many existing solutions provide monitoring and data visualization but do not include **real-time IoT-based remote access with automatic protection mechanisms**. In addition, limited research combines **continuous sensing, alert generation, LCD display, cloud monitoring, and relay-based load disconnection** into a single low-cost and user-friendly system.

Therefore, there is a need for an integrated monitoring system that enables **real-time transformer condition monitoring, remote accessibility, automatic fault detection, and immediate protective action**. The proposed **Real Time Transformer Monitoring System using IoT** addresses these limitations by combining multiple sensors, IoT connectivity, alert mechanisms, and automatic relay control to improve transformer reliability, safety, and maintenance efficiency.

IV. METHODOLOGY

The methodology of the **Real Time Transformer Monitoring System using IoT** is based on continuous sensing, real-time data processing, remote monitoring, and automatic protection of transformer operating conditions. The proposed system integrates multiple sensors, an embedded controller, and IoT communication technology to ensure efficient transformer health monitoring and fault prevention.

Initially, a regulated power supply is provided to energize all system components. The **Arduino UNO SMD** acts as the central controller and receives input signals from different monitoring sensors installed in the system. The **ZMPT voltage sensor** continuously measures transformer voltage, while the **current sensor** monitors load current conditions. Environmental conditions such as **temperature and humidity** are measured using the **DHT11 sensor**, and a **level sensor** is used to monitor transformer oil level.

The sensor readings are continuously collected and processed by the Arduino controller. The measured values are compared with predefined threshold limits to determine whether the transformer is operating under normal or abnormal conditions. The real-time data are displayed locally through an **LCD display** to provide instant status information.

For remote accessibility, the processed information is transmitted to an **IoT platform**, enabling users to monitor transformer conditions through mobile devices or web applications from any location. This supports continuous supervision and quick decision-making.

Whenever any parameter exceeds the permissible operating limit, the system activates a **buzzer** to generate an alert and simultaneously operates a **relay module** to disconnect the load and protect the transformer from damage. This methodology ensures early fault detection, improved reliability, reduced maintenance cost, and enhanced operational safety.

V. SYSTEM DESIGN

The block diagram of the **Real Time Transformer Monitoring System using IoT** illustrates the overall architecture developed for continuous transformer condition monitoring, fault detection, and remote supervision. The system integrates sensing devices, an embedded controller, display units, IoT communication, and protection components to ensure efficient transformer operation.

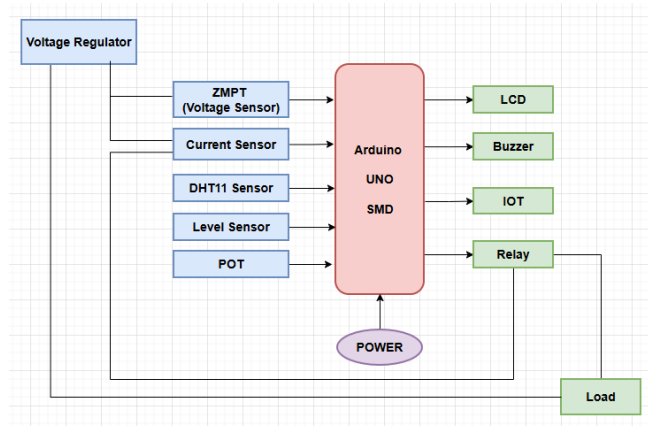

Figure 1: Block Diagram

The system is powered through a **Voltage Regulator**, which supplies stable and regulated power to all electronic components and ensures reliable system performance. The **Arduino UNO SMD** acts as the central control unit and is responsible for acquiring sensor data, processing measurements, controlling outputs, and managing communication with the IoT platform.

Several sensors are connected to the controller for monitoring important transformer parameters. The **ZMPT Voltage Sensor** continuously measures transformer voltage and detects abnormal voltage variations such as overvoltage or undervoltage conditions. A **Current Sensor** is used to monitor load current and identify overload situations that may affect transformer efficiency and safety.

A **DHT11 Sensor** is incorporated to measure environmental temperature and humidity, as excessive temperature can reduce insulation life and affect transformer performance. The system also includes a **Level Sensor** to monitor transformer oil level and identify leakage or insufficient oil conditions that may lead to overheating.

A **Potentiometer (POT)** is used for calibration and adjustment during testing and system implementation. All sensor readings are continuously collected and processed by the Arduino controller.

The measured parameters are displayed locally using an **LCD Display**, allowing operators to observe transformer conditions directly. For remote monitoring, the processed data are transmitted through an **IoT platform**, enabling users to access real-time transformer information from mobile devices or web applications.

To enhance protection, the system includes a **Buzzer** that generates alerts whenever any monitored parameter exceeds predefined safe limits. Additionally, a **Relay Module** is connected to control the transformer **Load**. During abnormal conditions such as excessive temperature, overload, voltage fluctuation, or low oil level, the relay automatically disconnects the load to prevent transformer damage.

Thus, the proposed block diagram provides an integrated solution for **real-time monitoring, remote accessibility, fault detection, and automatic transformer protection**, resulting in improved reliability, reduced maintenance effort, and enhanced operational safety.

VI. RESULT AND DISCUSSIONS

The **Real Time Transformer Monitoring System using IoT** was successfully designed and implemented to monitor important transformer operating parameters in real time. The developed system continuously measured **voltage, current, temperature, humidity, and oil level** using integrated sensors and processed the collected data through the **Arduino UNO SMD** controller. The measured values were displayed locally on an LCD screen and transmitted to an IoT platform for remote monitoring and analysis.

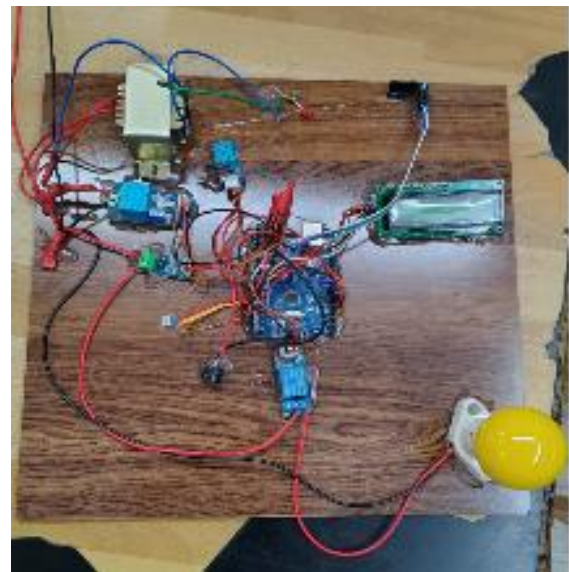

Figure 2: Proposed Hardware

During testing, the system operated effectively under different simulated transformer conditions. The **ZMPT voltage sensor** continuously monitored voltage variations and accurately detected abnormal voltage conditions. The **current sensor** measured load current and identified overload situations. The **DHT11 sensor** successfully monitored environmental temperature and humidity, while the **level sensor** detected changes in transformer oil level.

The IoT platform displayed real-time parameter updates and allowed users to monitor transformer status remotely through a mobile or web interface. The uploaded sensor data provided continuous observation and improved accessibility without requiring physical inspection of the transformer location.

When any operating parameter exceeded the predefined safety threshold, the system generated immediate alerts using the **buzzer module** and activated the **relay module** to disconnect the load automatically. This protection mechanism helped prevent transformer overheating, overload, and possible equipment failure.

The implemented system demonstrated stable operation and reliable communication between sensing units, controller, and IoT monitoring platform. The real-time monitoring capability improved response time for fault detection and reduced dependence on manual inspection.

Hardware Result Discussion

- Sensors continuously acquired transformer operating data.
- LCD displayed real-time values locally.
- IoT dashboard updated live parameter readings.

- Buzzer generated warning alerts during fault conditions.
- Relay disconnected load automatically for transformer protection.

The obtained results confirm that the proposed **Real Time Transformer Monitoring System using IoT** provides an effective and low-cost solution for continuous transformer supervision. The system improves operational safety, minimizes maintenance effort, supports predictive maintenance, and enhances the reliability and lifespan of transformer systems.

VII. CONCLUSION

The **Real Time Transformer Monitoring System using IoT** was successfully designed and implemented to provide continuous monitoring and protection of transformer operating conditions. The developed system effectively monitored important parameters such as **voltage, current, temperature, humidity, and oil level** using integrated sensors and processed the collected information through the **Arduino UNO SMD** controller.

The integration of IoT technology enabled real-time data transmission and remote accessibility, allowing users to observe transformer performance from any location. The system displayed live parameter values on the LCD and generated immediate alerts through a buzzer whenever abnormal conditions were detected. Additionally, the relay-based protection mechanism automatically disconnected the load to prevent transformer damage and improve operational safety.

The obtained results demonstrated that the proposed system can reduce manual inspection, support early fault detection, minimize maintenance effort, and improve transformer reliability and efficiency. The implementation of real-time monitoring and automatic protection contributes to extending transformer lifespan and supports the development of intelligent and smart power distribution systems. Overall, the proposed solution provides a low-cost, reliable, and efficient approach for modern transformer condition monitoring and management.

REFERENCES

- [1] M. R. Msane, B. Thango, and K. Ogudo, "Internet of Things (IoT)-Based Transformer Condition Monitoring: A Systematic Literature Review," *Applied Sciences*, vol. 14, no. 21, pp. 1–29, 2024.
- [2] Y. Zhang, X. Wang, and J. Li, "Transformer Monitoring with Electromagnetic Energy Transmission and Wireless Sensing," *Sensors*, vol. 24, no. 5, pp. 1–21, 2024.
- [3] M. Ragavan, S. Kumar, and R. Balaji, "Recent Advances in IoT-Based Transformer Health Monitoring: A Review," *International Journal of Scientific Research and Engineering Development*, vol. 6, no. 4, pp. 112–119, 2023.
- [4] S. U. Rehman, M. Tariq, and A. Khan, "IoT-Based Distribution Transformer Monitoring and Protection System," *Electrical and Control Engineering*, vol. 14, no. 2, pp. 45–53, 2023.
- [5] S. Dash, P. Mohapatra, and A. Mishra, "Smart Transformer Health Monitoring and Control System Using IoT Technology," *Applied Sciences*, vol. 13, no. 18, pp. 1–16, 2023.
- [6] M. D. Eqbal, A. Kumar, and S. Singh, "IoT-Based Transformer Fault Classification Using Electronic Nose and ANFIS Techniques," *Frontiers in Energy Research*, vol. 10, pp. 1–15, 2022.
- [7] J. Ramesh, P. Kannan, and R. Venkatesh, "Smart Distribution Transformer Monitoring and Management System Using Machine Learning," *Energies*, vol. 15, no. 21, pp. 1–19, 2022.
- [8] S. Patel, R. Shah, and D. Mehta, "UPIoT-Based Power Monitoring of Transformer Using Cloud Connectivity," *Materials Today: Proceedings*, vol. 62, pp. 4689–4694, 2022.
- [9] D. S. Shastrimath, P. R. Patil, and M. Kulkarni, "IoT-Based Condition Monitoring of Transformer," *International Journal of Engineering Research & Technology (IJERT)*, vol. 11, no. 6, pp. 523–528, 2022.
- [10] N. Mishra, A. Verma, and S. Gupta, "Survey on IoT-Based Transformer Health Monitoring Techniques," *International Journal of Engineering and Advanced Technology*, vol. 11, no. 5, pp. 50–58, 2022.
- [11] A. Gupta and V. Sharma, "Transformer Health Monitoring and Protection Using Wireless Sensor Networks," *IEEE Access*, vol. 9, pp. 116432–116445, 2021.
- [12] S. Kumar and V. Patel, "IoT-Based Transformer Condition Monitoring for Smart Grid Applications," *International Journal of Power Electronics and Drive Systems*, vol. 12, no. 3, pp. 1680–1688, 2021.
- [13] R. K. Gupta and S. Verma, "Cloud-Based Transformer Monitoring and Automatic Protection System," *International Journal of Electrical Power and Energy Systems*, vol. 130, pp. 106907–106918, 2021.
- [14] P. Sharma and R. Singh, "Embedded IoT Platform for Real-Time Transformer Monitoring," *Microprocessors and Microsystems*, vol. 80, pp. 103550–103561, 2021.
- [15] M. S. Hossain and G. Muhammad, "Cloud-Assisted Industrial Monitoring Using Internet of Things," *IEEE Internet of Things Journal*, vol. 7, no. 4, pp. 3216–3224, 2020.

Citation of this Article:

Nikhil Jadhav, Pramod Bhatane, Rohan Sarde, Soham Waghmare, & Narendra Neginhalr. (2026). Real Time Transformer Monitoring System. *International Research Journal of Innovations in Engineering and Technology - IRJIET*, 10(5), 720-725. Article DOI <https://doi.org/10.47001/IRJIET/2026.105096>
