

IoT Based Smart Grid Control and Energy Monitoring

¹Vilas S. Bugade, ²Sakshi B. Kilbile, ³Harshada S. Gaikwad, ⁴Pooja A. Nalawade, ⁵Pradnya D. Rahane

^{1,2,3,4,5}Department of Electrical Engineering, Marathwada Mitra Mandal's College of Engineering, Pune, India

E-mail: vilasbugade@mmcoe.edu.in, sakshikilbile2022.elect@mmcoe.edu.in, harshadagaikwad2022.elect@mmcoe.edu.in,
poojanalawade2022.elect@mmcoe.edu.in, pradnyarahane2022.elect@mmcoe.edu.in

Abstract - The Internet of Things (IoT) has emerged as a key technology for converting conventional power grids into smart, efficient, and reliable energy systems. This study proposes an IoT based intelligent power grid control and energy monitoring system incorporating connected devices, current and voltage sensors, relays, and advanced analytics capable of providing dynamic state estimation, protection, control, and optimization of energy consumption. The proposed system gathers real-time data regarding energy generation, distribution, and load parameters at the individual appliance, building, and overall grid levels, and transmits the same using a Wi-Fi module to a web-based platform accessible through an Android device using a unique channel ID. Such data analytics enable dynamic load management, demand response, peak load reduction, and improvement in grid stability, in addition to offering overcurrent and under voltage protection through relay-based mechanisms. The proposed system also provides integration and efficient utilization of renewable energy sources like solar and wind power. Real-time oversight and remote control facilitate addressing issues such as unpredictable loads and load shedding, thus helping to develop smart city energy infrastructure.

Keywords: Internet of Things (IoT), Smart Grid, Intelligent Power Grid, Energy Monitoring System, Smart Energy Management, Real-Time Data Analytics, Dynamic Load Management, Demand Response, Grid Stability, Energy Optimization, Renewable Energy Integration.

I. INTRODUCTION

Many developing countries are still facing regular power fluctuations and interruptions owing to the increasing demand for electricity and absence of real-time monitoring systems. The conventional power grid system relies on manual control and switching, which may cause delays, power grid failures, and possible hazards to maintenance personnel dealing with high voltage situations. To address these issues, smart power grid technology has been developed as a reliable solution.

Smart grid technology combines communication networks, sensors, wireless surveillance systems, and computerized control systems to enable efficient energy

transmission, fast fault detection, and quick power restoration. Smart grid technology also enables the connection of renewable energy sources, including solar and wind energy, enabling bidirectional power transmission between consumers and power suppliers.

The proposed system focuses on monitoring essentials characteristics such as voltage, current, temperature, and humidity, through sensors, and provides automatic switching between primary and backup transformers in the case of faults. By leveraging automation and real-time monitoring, the proposed system improves the performance, reliability, and safety, of power grids.

II. LITERATURE REVIEW

Numerous research works have been conducted on the IoT-based smart grid and energy monitoring systems to improve efficient and reliability. An IoT-enabled smart energy management system utilizing the ESP8266 Node MCU, current, and PIR sensors, GSM modules, and relay modules was designed to enable real-time energy monitoring and remote control of appliances through the Thing Speak platform. Although efficient for monitoring and control, the systems reliance on constant internet connectivity restricts its usually mainly to small-scale application.

Muhammad Khalid et al. presented a methodological approach for incorporating renewable energy sources (RES) into smart grids to improve flexibility and reliability. The study addressed issued like unpredictability of Inexhaustible energy resources and absence of inertia support. However, the following limitations were found in addressing design complexity, operational uncertainties, and grid stability with varying renewable energy output.[3]

Goudarzi et al. presents a review of IoT-enable smart system, identification new applications, challenges, and potential opportunities. The study highlighted major concerns such as the risk of cybersecurity threats, data privacy, and difficulties in integrating with existing grid infrastructure. The authors proposed the use of innovative technologies like blockchain, machine learning, and 5G communication for improve security, compatibility, and robustness.[7]

Uddin et al. investigated microgrid (MG) system in terms of control schemes, renewable energy integration, load balancing, and energy storage management. Although microgrids improve flexibility and efficiency, the following challenges were identified. High implementation costs, inadequate communication infrastructure, and the absence of standardized protocols. The authors proposed improvement in control system, protection schemes, and the integration of innovative technologies to improve overall performance.[8]

The literature review highlights the significance of real-time monitoring, automation, renewable energy integration, and cybersecurity in smart grid development, while also emphasizing existing challenges of complexity, stability, cost, and secure communication.

III. METHODOLOGY

(A) Hardware Prototype

The proposed IoT energy monitoring system consists of a hardware prototype that enables the connection of a consumer load and the evaluation of its electrical performance characteristics. The hardware setup utilizes an ESP32 microcontroller, a ZMPT101B which is known as a voltage sensor, an ACS712 which is known as a current sensor, and a 5V relay module.

The voltage and current sensors are attached to the load to keep track of real-time electrical features like voltage, current, power, and how much energy is being used. The ESP32 microcontroller reads the analog signals from the sensor using its in-built Analog-to-Digital converter (ADC) module.

Taking advantages of its Wi-Fi module, the ESP32 sends the measured data wirelessly to the Blynk cloud server uses the MQTT protocol. MQTT is a lightweight communication protocol for efficient data collection from devices and transmission to the server.

The hardware prototype is tested under different load condition (on-load and off-load conditions) to test the performance of the system. The relay module enables remote control of the load using the Blynk mobile app. The load status is indicated digitally using “1” for the load ON position and “0” for the load OFF position, making it easy for the user to understand the status of the system.

(B) System overview

This system has been developed based on the combination of three fundamental functional blocks;

(C) Monitoring Block

At the heart of monitoring is the current sensor (ACS712) and the voltage detection circuit (ZMPT101B), which are all connected to the consumer load. These sensors monitor electrical parameters and convey the information to the ESP32 board.

Communication Block ESP32 WLAN module

The ESP32 WLAN module handles the communication part used for communication block. MQTT protocol is used to send the real-time electrical data to the cloud server. This bridges the sensing block and the cloud application.

Analysis Block

In the analysis section, a remote mobile app using the Blynk framework can be employed. It provide the capability for the user to view or visualized the data, such as voltage levels, current levels, power levels, rate of consumption, as well as the load levels. In addition, the user can observe the level of energy consumption in hourly, weekly and monthly consumption.

(D) System Design

This setup is basically a Wi-Fi node composed of these part;

- A consumer load
- A voltage sensor (ZMPT101B)
- A current sensor (ACS712)
- An ESP32 module
- Relay module

Programming is done using the Arduino Integrated Development Environment’s ESP32 microcontroller. It reads the value from the sensors, calculates the electrical parameters, and stores some data in its memory. It is then uploaded to the cloud server.

Key capability of the ESP32:

- Dual-core Tensilica LX6 processor, Up to 240MHz
- Built-in Wi-Fi and Bluetooth
- Generous number of GPIO pins
- An internal ADC for analog signal
- Support for SPI,
- UART communicational protocols,
- SSL/TLS security supports.

All these make the ESP32 suitable for use in secure and efficient IoT-based energy monitoring application.

The block diagram as follows:

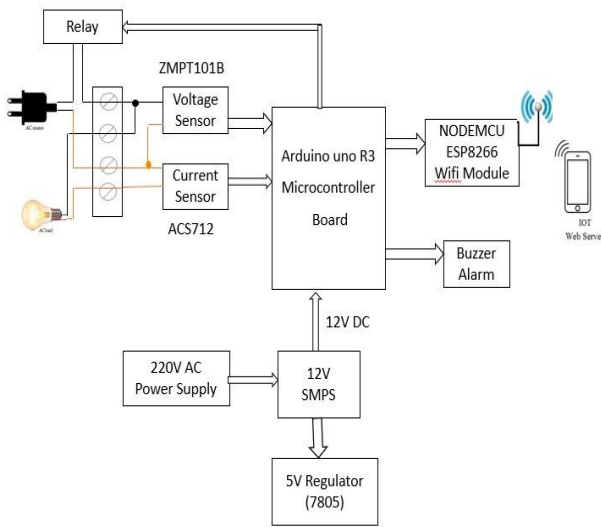

Figure 1: Block diagram of Smart Micro Grid

Sensors and Component Description:

i) Node ESP32 Wireless LAN Controller

The ESP32 is high-performance micro-controller module that has Wi-Fi and Bluetooth capability to integrated into it. It has a dual-core TensilicaLX6 microprocessor that runs at speeds of up to 240 MHz, making it capable of handling complex tasks efficiently. The ESP32 supports a variety of communication protocols such as SPI, I2C, and UART, making it easy to integrate with sensors and other peripherals.

The ESP32 has variety of general purpose Input/Output (GPIO) pins and comes with an Analog-to-Digital Converter (ADC) that makes it easy to connect to analog sensors. The ESP32 also has built-in security protocols such as Secure Sockets Layer (SSL) and Transport Layer Security (TLS), make it perfect for secure IoT applications. The ESP32 uses very low power and has a compact size, making it great for embedded energy monitoring projects.



Figure 2: Node MCU ESP32 Wi-Fi Controller

ii) Voltage Sensor (ZMPT101B)

The ZMPT101B is a high-accuracy alternating current (AC) voltage sensor module that is used to measure voltages between 0-250 V AC. It uses voltage transformer that offers high accuracy and minimal temperature drift.

The module includes a transformer, a rectifier, and a voltage regulation circuit. The transformer reduces the high AC voltage to a lower value that can be measured. The rectifier is used to convert the alternating current to direct current, while the voltage regulator is used to regulate the output voltage. The conditioned analog output is then connected to the ADC input of the ESP32 to measure the voltage.

The ZMPT101B voltage sensor commonly used in power measurement and smart grid system because of its accuracy and reliability.

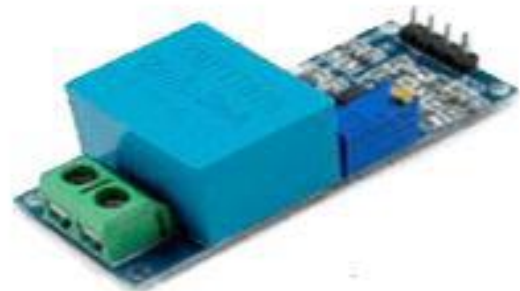

Figure 3: Voltage Sensor (ZMPT101B)

iii) Current Sensor (ACS712)

The ACS712 is a current sensor measures the current passing through a conductor by using the Hall Effect. uses the Hall Effect. It gives an output voltage that changes based on the amount of current, with a specific voltage increases for each ampere of current.

The ACS712 operates using a single supply and provides high accuracy with low offset error. The device is offered in various current range versions, from a few amperes to 30A. The ACS712 has a simple three-pin interface (VCC, GND, Signal), which makes it easy to integrate with microcontrollers.

The ACS712 is commonly used in motor control, energy, and power measurement applications.

V. RESULTS

The IoT-based Smart Grid Monitoring and Protection System proved to work well in real-time monitoring and detecting faults. It kept track of important electrical values like voltage, current, and power using built-in sensors and sent the information to a web-based interface through the ESP8266 Wi-Fi module. The tests showed the system could correctly find issues such as high voltage, low voltage, and too much load. For example, if the voltage went above a set limit like 255.3 volts, the system recognized it as high voltage and automatically turned off the power by sending a trip signal. It also found low voltage situations, like 53.65 volts, and overload cases, handling them with the relay protection circuit.



Figure 4: Current sensor (ACS712)

iv) Relay Module

The Channel-1 5V Relay Module used for controlling loads to proposed system. The module acts as an electromagnetic switch, enabling a low-voltage control signal from the ESP32 to manage high-voltage or high-current loads.

When a control signal is generated by the microcontroller, the relay coil is energized, leading to the corresponding opening or closing of the contacts. The module has a driver circuit that provides sufficient current to energized the relay coil.

The relay board is widely used in application such as home automation, industrial control system, and smart energy management. The board provides a reliable and affordable solution for the remote control of electrical appliances.

Voltage(V)	Current(A)	Power(W)	Fault	Trip
226.60	0.28	63.4	Null	No Trip
221.66	0.46	101.9	Overload	Trip
53.65	0.09	4.82	Under voltage	Trip
240.12	0.50	120.05	Overload	Trip
255.3	0.55	140.4	Over Voltage	Trip

When everything was working normally, the system provided steady reading and didn't send any trip signal, showing that it was dependable. The real-time dashboard showed the measured values including voltages, current, power usage, and any faults, allowing for ongoing remote monitoring. During testing, the system quickly acted on faults by cutting off the affected part, which helped avoid damage to equipment and kept things safe. The results show that this IoT-based system helps make the grid more reliable, safer, and efficient by detecting faults fast, automatically protecting the system, and allowing remote monitoring. These results prove that the system is effective for use in modern smart grids.



Figure 5: Relay module

IV. SOFTWARE -BLYNK PLATFORM

Blynk is an opensource Internet of Things (IoT) platform that is used for the storage, analysis, and retrieval of real-time energy information. The ESP32 module transmits measurements for voltage, current, and power to the Blynk cloud using Wi-Fi communication based on the MQTT protocol.

The Blynk platform displays electrical readings and provides a convenient interface for the monitoring and control of loads. The platform allows the analysis of energy usage behavior and facilities dynamic billing calculations and advance demand-supply management.

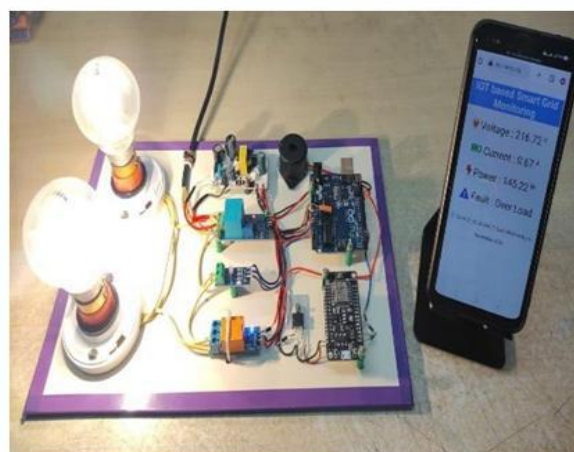

Figure 6: System under fault detection

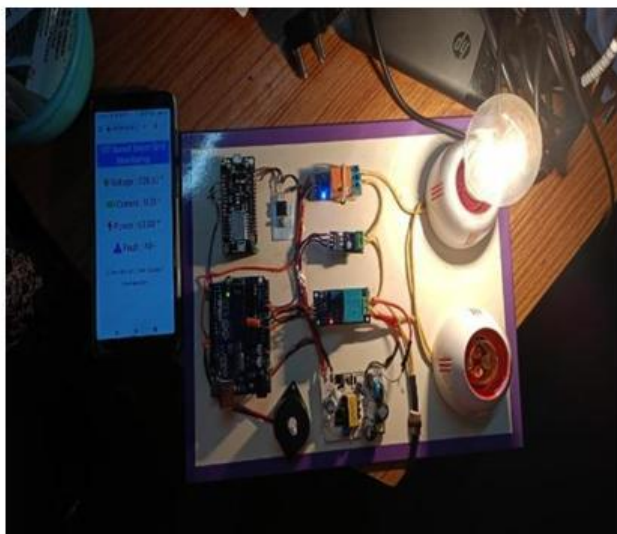

Figure 7: System under normal condition

VI. CONCLUSION

A successful IoT-based energy monitoring control system using the IoT framework was developed and tested across different levels of loads. Voltages, current, and power were monitored and tracked effectively. In addition, these parameters were shown in real-time using the Blynk app. Further, the system can turn devices and loads on and off, and it also provides protection from high voltage situations. For its implementation, it is embedded, making it cost-effective and energy efficient while remaining portable. In the future, it can be implemented to monitor the energy of an entire building, as well as at the points where transformer are located.

ACKNOWLEDGMENT

The technical planning and research work for the project were undertaken with guidance by **Dr. Vilas S. Bugade**, Associate Professor in the Department Electrical Engineering at the College of Engineering, Pune, affiliated to the Marathwada Mitra Mandal. He provided guidance and support to the author in completing the research project.

REFERENCES

- [1] F. Khan, M. A. B. Siddiqui, A. U. Rehman, J. Khan, M. T. Sadiq, and A. Asad, "IoT-Based Power Monitoring System for Smart Grid Applications," *COMSATS University Islamabad, Abbottabad Campus, Pakistan*, pp. 765-771, 2020.
- [2] D. Gavrilor, M. Gouzman, and S. Luryi, "Monitoring Large-Scale Power Distribution Grids," DOI: 10.1016/j.sse2019.03.12
- [3] M Khalid, "Smart grids and renewable energy systems: Perspectives and grid integration challenges," *Energy Strategy Reviews*, vol.51, p. 101299, Jan 2024.
- [4] A.Azizi, S. Peyghami, H. Mokhtari, and F. Blaabjerg, "Autonomous and Decentralized Load Sharing and Energy Management Approach for DC Microgrids," DOI:10.1016/j.epr.2019.106009.
- [5] C.C. Obasi, O. B. Odeyinde, J. J. Agidani, V. O. Ibiom, and C. O. Ubedike, "Design and Implementation of Microcontroller-Based Programmable Power Changeover," *Journal of Energy Technologies and Policy*, vol. 6, no. 12, 2015.
- [6] Sachan, "GSM Based Automated Embedded System for Monitoring and Controlling of Smart Grid," vol. 7, no. 12, 2013.
- [7] A.Goudarzi, F. Ghayoor, M Waseem, S. Fahad, and I. Trarore, "A survey on IoT-Enabled Smart Grids: emerging, applications, challenges, and outlook Energies," vol.15, no. 19, p. 6984, Sep. 2022.
- [8] M. Uddin, H. Mo, D. Dong, S. Elsayah, J. Zhu, and J. M. Guerrero, "Microgrids: A review, outstanding issues and future trends," *Energy Strategy Reviews*, vol. 49, p. 101127, Jul. 2023.
- [9] R. Ma, H.-H. Chen, Y. R. Huang, P. Li, and Q. Lao, "Smart Grid Communication: challenge and opportunities," *IEEE Transactions on Smart Grid*, vol.4 no. 4, pp. 1878-1887, 2013.
- [10] D. Gavrilor, M. Gouzman, and S. Luryi, "Monitoring Large-Scale Power Distribution Grids," DOI: 10.1016/j.sse2019.03.12.

Citation of this Article:

Vilas S. Bugade, Sakshi B. Kilbile, Harshada S. Gaikwad, Pooja A. Nalawade, & Pradnya D. Rahane. (2026). IoT Based Smart Grid Control and Energy Monitoring. *International Research Journal of Innovations in Engineering and Technology - IRJIET*, 10(6), 71-75. Article DOI <https://doi.org/10.47001/IRJIET/2026.106007>
