

Smart Device-Based Street Light Monitoring and Controlling System

¹Prof. Sachin C. Rathod, ²Aditya A. Auchare, ³Premraj B. Mugade

¹Asst. Professor, Electronics and Telecommunication Engineering, Navsahyadri College of Engineering, Pune, Maharashtra, India

^{2,3}Student, Electronics and Telecommunication Engineering, Navsahyadri College of Engineering, Pune, Maharashtra, India

Abstract - The Smart Device-Based Street Light Monitoring and Controlling System is an intelligent and energy-efficient solution developed to automate street lighting and enable real-time monitoring using Internet of Things (IoT) technology. Conventional street lighting systems operate through manual control or fixed schedules, resulting in unnecessary energy consumption and increased maintenance costs. The proposed system utilizes an ESP32 microcontroller, Light Dependent Resistor (LDR), Passive Infrared (PIR) sensor, relay module, and LCD display to achieve automated street light operation. The LDR sensor detects ambient light intensity to control day and night switching, while the PIR sensor identifies vehicle or pedestrian movement to activate lighting only when required. IoT connectivity enables remote monitoring and control through a cloud platform or mobile application. The developed system improves energy utilization, reduces operational costs, minimizes manual intervention, and supports sustainable and intelligent smart city infrastructure.

Keywords: Smart Street Light, Internet of Things (IoT), ESP32, LDR Sensor, PIR Sensor, Energy Efficiency, Remote Monitoring, Automation, Smart City, Street Light Control.

I. INTRODUCTION

Street lighting is an essential component of modern urban and rural infrastructure as it improves road safety, enhances visibility during nighttime, and supports public security. Conventional street lighting systems generally operate using fixed timers or manual switching methods, causing unnecessary power consumption and increased maintenance expenses. Continuous operation of street lights even during low traffic conditions leads to significant energy wastage and inefficient utilization of electrical resources. With the increasing demand for sustainable energy solutions and the rapid development of smart cities, intelligent street lighting systems have become an important area of research and implementation.

The Smart Device-Based Street Light Monitoring and Controlling System is developed to provide an automated and intelligent solution for efficient street light management. This system utilizes modern technologies such as the Internet of Things (IoT), ESP32 microcontroller, Light Dependent Resistor (LDR), Passive Infrared (PIR) sensor, relay modules, and wireless communication to create a smart and adaptive street lighting infrastructure. The integration of sensing, control, and communication technologies enables automatic street light operation based on environmental conditions and real-time movement detection.

The proposed system uses an LDR sensor to continuously monitor ambient light intensity. When natural light decreases below a predefined threshold during evening or nighttime, the system automatically activates the street lighting. Similarly, the PIR sensor detects the movement of vehicles and pedestrians and allows selective illumination of street lights only when required. This approach significantly reduces energy consumption and extends the operational lifespan of lighting equipment.

The ESP32 microcontroller serves as the central control unit due to its built-in Wi-Fi capability, high processing performance, and support for IoT applications. Through IoT connectivity, the system allows remote monitoring and control using a cloud platform, web dashboard, or mobile application. Administrators can observe real-time lamp status, energy usage, and maintenance alerts from remote locations, improving operational efficiency and reducing manual inspection efforts.

Smart street lighting systems offer several advantages over traditional lighting infrastructure, including lower electricity costs, reduced carbon emissions, improved maintenance management, and enhanced public safety. By collecting and transmitting operational data, these systems also support data-driven decision-making and predictive maintenance strategies.

This project contributes to the development of sustainable and intelligent urban infrastructure by implementing an

automated street light monitoring and controlling system capable of reducing energy losses while improving reliability and convenience. The proposed solution can be effectively deployed in smart cities, highways, residential colonies, campuses, and rural road networks to achieve efficient and environmentally responsible lighting management.

II. LITERATURE REVIEW

The increasing demand for energy conservation, sustainable infrastructure, and smart city development has encouraged researchers to develop intelligent street lighting systems using **Internet of Things (IoT), embedded controllers, wireless communication, and sensor-based automation technologies**. Conventional street lighting systems generally rely on manual operation or fixed schedules, resulting in unnecessary power consumption, increased operational expenses, and inefficient maintenance practices. To overcome these limitations, recent research has focused on designing adaptive lighting systems capable of automatic operation, real-time monitoring, remote accessibility, and predictive maintenance. The following literature review presents recent contributions related to smart street light monitoring and controlling technologies.

Achar et al. (2024) [1] conducted a comprehensive survey on **Smart Automated Highway Lighting Systems using IoT technologies**. Their research examined different intelligent lighting techniques including sensor-based illumination control, adaptive brightness adjustment, cloud integration, and communication frameworks. The study emphasized that automated lighting systems can significantly reduce electrical energy consumption by adjusting light intensity according to environmental and traffic conditions. The authors also highlighted that IoT-based monitoring enables authorities to detect faults remotely and improve maintenance planning. However, practical implementation challenges such as installation cost, communication reliability, and system scalability were identified as limitations for large-scale deployment.

Kouah et al. (2024) [2] proposed an **IoT-based Multi-Agent Smart Street Lighting Control System** that utilizes distributed intelligence for autonomous operation. Their architecture allows individual lighting nodes to communicate and make decisions independently while remaining connected to a centralized monitoring system. The proposed model demonstrated improved adaptability to environmental changes and enhanced response time compared to conventional systems. The research concluded that decentralized control improves operational efficiency, although implementation complexity and network synchronization remain significant concerns.

Sasidevi et al. (2024) [3] developed an **Intelligent Street Lighting System using IoT for Adaptive Brightness Control and Fault Management**. The proposed system incorporated real-time sensing, automatic brightness adjustment, and continuous monitoring of lamp conditions. Their work demonstrated that adaptive illumination effectively minimizes electricity wastage during periods of low traffic while maintaining road safety. Additionally, the inclusion of automated fault detection reduced maintenance delays and improved service reliability. The study recommended integrating cloud analytics for further optimization.

Balasubramanian (2023) [4] introduced a **Nano Uno–Machine Learning–IoT based Smart Street Light Monitoring System** with centralized control capabilities. Their research integrated machine learning algorithms with IoT infrastructure to predict usage patterns and optimize street light operation. The system achieved better energy management and enhanced automation through intelligent decision-making. However, increased computational requirements and hardware complexity were reported as challenges for practical deployment in low-cost applications.

Saputra and Surapati (2024) [5] presented an **ESP32-based Automatic Public Street Lighting Control System integrated with IoT Monitoring**. Their system collected environmental data and automatically adjusted lighting conditions based on real-time inputs. The implementation demonstrated improvements in operational flexibility, energy conservation, and remote accessibility through web-based monitoring. Although the system performed effectively, long-term scalability and reliability under varying weather conditions require further investigation.

Yaichi et al. (2024) [6] proposed an **IoT-based Smart Street Lighting System using ESP-NOW Communication Protocol** for enhanced energy efficiency. Their system enabled communication among multiple street lighting units without requiring extensive network infrastructure. Experimental results showed reduced communication delay and lower power consumption. The authors concluded that wireless communication protocols can play a significant role in future smart city deployments.

Biswas and Hardik (2024) [7] developed an **IoT-based Retrofit Smart Street Lighting Solution** aimed at transforming traditional street lights into intelligent systems without complete infrastructure replacement. Their approach introduced sensor-based control and remote monitoring features while minimizing implementation costs. The study demonstrated that upgrading existing street lighting infrastructure provides an economical path toward smart city transformation.

Domínguez-Bolaño *et al.* (2024) [8] designed an **IoT System for Smart Campus Infrastructure Management**, emphasizing centralized device control and real-time visualization of operational data. Although the system was developed for campus applications, the architecture demonstrated concepts directly applicable to street lighting systems, including remote monitoring, cloud connectivity, and automated control.

Vales *et al.* (2024) [9] investigated **Fine Time Measurement (FTM) technology implemented using ESP32 devices** to improve communication performance in IoT applications. Their study demonstrated enhanced synchronization accuracy and reduced communication latency, which are important requirements for large-scale distributed smart lighting systems. The research suggested that improved communication mechanisms can support more reliable monitoring and control.

Casado Diez (2024) [10] developed **FreeDSM, an IoT-based Environmental Light Monitoring Platform using ESP32**. The project focused on continuous light intensity monitoring and cloud-based data analysis for intelligent environmental management. Their findings confirmed that real-time sensing and wireless data transmission can improve decision-making in automated lighting applications.

Recent studies collectively indicate that integrating **sensor technologies, IoT connectivity, wireless communication, and intelligent control algorithms** provides substantial improvements in street lighting performance. Existing research demonstrates benefits such as reduced power consumption, improved maintenance efficiency, remote accessibility, and enhanced operational reliability. However, many available solutions focus either on monitoring or automation individually and often require complex architectures or expensive infrastructure.

Therefore, the proposed **Smart Device-Based Street Light Monitoring and Controlling System** aims to overcome these limitations by integrating **ESP32, LDR sensor, PIR motion sensor, relay-based switching, LCD status display, and IoT-enabled remote monitoring into a single low-cost and energy-efficient platform**. The proposed system is designed to provide automated operation, reduced electricity consumption, real-time monitoring, improved reliability, and practical implementation suitable for both urban and rural smart lighting applications.

III. GAP ANALYSIS

From the literature review, it is observed that existing **IoT-based smart street lighting systems** mainly focus on

either **automatic control, energy optimization, or remote monitoring** individually. Many systems rely only on timer-based operation or ambient light sensing and do not effectively utilize **real-time motion detection** for dynamic lighting control.

Additionally, several existing solutions require **complex architectures, expensive communication modules, and higher maintenance costs**, making them less suitable for practical deployment in urban and rural areas. Most studies also provide limited integration of **ambient light sensing, motion-based control, local status display, and IoT monitoring within a single low-cost platform**.

Therefore, the proposed **Smart Device-Based Street Light Monitoring and Controlling System** addresses these limitations by integrating **ESP32, LDR sensor, PIR sensor, relay control, LCD display, and IoT connectivity** into one intelligent system. The proposed approach aims to achieve **automatic street light operation, real-time monitoring, reduced energy consumption, lower maintenance cost, and improved reliability** for smart city applications.

IV. SYSTEM DESIGN

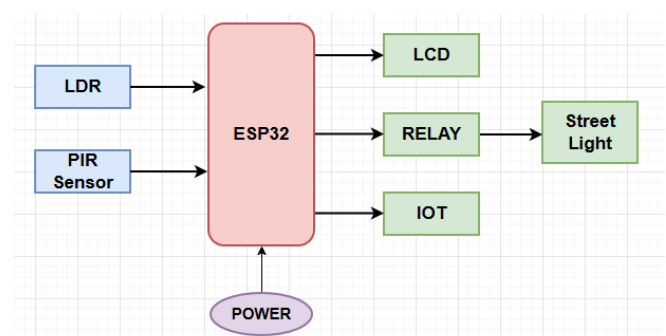

Figure 1: Block Diagram

The **Smart Device-Based Street Light Monitoring and Controlling System** is designed to provide intelligent and automated street light operation using **ESP32, IoT connectivity, LDR sensor, PIR sensor, relay module, and LCD display**. The system continuously monitors environmental conditions and controls street lighting efficiently to reduce energy consumption and improve operational reliability.

The **power supply unit** provides regulated power to all components of the system including the ESP32 microcontroller, sensors, relay module, LCD display, and street light setup. Proper power regulation ensures stable operation of the entire system.

The **ESP32 microcontroller** acts as the central processing and control unit of the system. It receives input signals from the LDR and PIR sensors, processes the data, makes control decisions, and sends output signals to operate the relay and communicate with the IoT platform.

The **LDR (Light Dependent Resistor) sensor** is used to detect surrounding light intensity. It continuously measures ambient lighting conditions and sends the information to the ESP32. During daytime, when sufficient natural light is available, the street lights remain OFF. When ambient light decreases during evening or nighttime, the system enables automatic street light control.

The **PIR (Passive Infrared) sensor** is responsible for detecting movement of vehicles or pedestrians. Once nighttime is detected by the LDR sensor, the PIR sensor becomes active. When motion is identified, the sensor sends a signal to the ESP32, which initiates street light operation.

The **relay module** functions as an electronic switching device that receives control signals from the ESP32 and controls the street light load accordingly. The relay safely isolates the low-voltage control circuit from the street lighting power circuit.

An **LCD display** is incorporated to provide real-time system information such as ambient light status, motion detection status, street light ON/OFF condition, and communication status. This allows users to monitor system operation locally.

The **IoT module integrated through ESP32 Wi-Fi connectivity** enables remote monitoring and controlling of the street lighting system through a cloud dashboard or mobile application. Operational data such as street light status, energy usage, and system conditions can be monitored remotely in real time.

Thus, the proposed block diagram represents an **automated, sensor-based, and IoT-enabled street lighting system** that improves energy efficiency, minimizes manual intervention, reduces maintenance effort, and supports smart city infrastructure development.

V. RESULT AND DISCUSSIONS

The **Smart Device-Based Street Light Monitoring and Controlling System** was successfully designed, implemented, and tested using **ESP32, LDR sensor, PIR sensor, relay module, LCD display, and IoT connectivity**. The developed system was evaluated under different environmental and operating conditions to verify automatic street light control,

motion detection capability, and remote monitoring performance. The experimental results confirmed that the proposed system operates effectively while reducing unnecessary energy consumption.

A. Hardware Implementation Result

The complete prototype was developed by integrating the ESP32 controller with sensors, display module, relay unit, and street light model. The hardware setup was powered and tested to verify communication and system functionality.

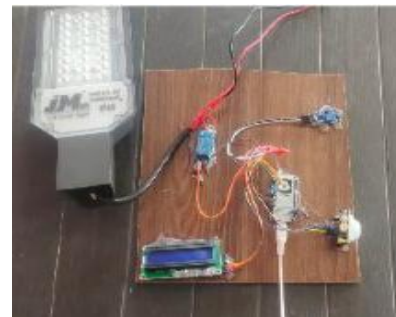

Figure 2: Hardware Setup

The hardware setup consists of an ESP32 microcontroller connected to an LDR sensor for ambient light sensing, a PIR sensor for motion detection, a relay module for switching the street light load, and an LCD display for status indication. The prototype was assembled and tested successfully. The ESP32 continuously collected data from sensors and executed control actions based on predefined conditions.

- Successful initialization of all hardware modules.
- Stable communication between sensors and ESP32.
- Reliable switching of street lights using relay control.
- Continuous display of system status on LCD.

B. Street Light Automatic Control Result

The automatic control feature was tested under different lighting conditions.



Figure 3: Street Light Operation Result

The LDR sensor continuously measured ambient light intensity. During daytime conditions, high light intensity values were detected and transmitted to the ESP32. Based on this input, the controller kept the street light switched OFF.

When environmental brightness reduced below the threshold level during evening or nighttime, the ESP32 automatically enabled street light control mode.

- Daylight Condition → Street Light OFF
- Night Condition → Street Light activated automatically
- Automatic switching reduced unnecessary energy consumption.

C. Motion Detection Result

The PIR sensor was used to detect vehicle or pedestrian movement.

Once night conditions were detected, the PIR sensor monitored movement near the lighting area. Whenever motion was detected, the sensor transmitted a signal to the ESP32, which immediately activated the relay and switched ON the street light.

After the movement stopped and no further activity was detected, the controller automatically switched OFF the light after a preset delay period.

- Motion Detected → Street Light ON
- No Motion → Street Light OFF
- Reduced energy wastage during low traffic periods.

D. LCD Display Result

The LCD display was used to provide local monitoring of system operation.



Figure 4: LCD Display Output

The LCD displayed current operating conditions including ambient light condition, movement status, and street light operation. This provided users with immediate visual feedback without requiring access to the IoT dashboard.

- Real-time display updates.
- Easy monitoring of system conditions.
- Improved user interaction.

E. IoT Monitoring Result

The developed system was integrated with IoT functionality using ESP32 Wi-Fi communication.



Figure 5: IoT Dashboard Screenshot

Sensor readings and street light status were transmitted to the IoT platform in real time. The dashboard displayed operational information including lamp status, ambient light condition, motion detection results, and device connectivity.

Users could monitor system operation remotely and observe changes in lighting conditions from any location.

- Successful wireless data transmission.
- Remote monitoring capability achieved.
- Improved maintenance and operational efficiency.

F. Discussion

The experimental results demonstrate that the proposed **Smart Device-Based Street Light Monitoring and Controlling System** operated successfully under different test conditions. The integration of **LDR and PIR sensors** enabled intelligent lighting decisions based on environmental and movement conditions.

The **ESP32 controller** effectively processed sensor data and controlled the relay operation in real time. The **IoT monitoring feature** provided additional flexibility by allowing remote supervision and reducing manual inspection requirements.

Compared with conventional street lighting systems, the proposed system achieved:

- Reduced electricity consumption
- Automatic street light operation
- Motion-based intelligent lighting
- Real-time monitoring through IoT
- Lower maintenance effort
- Improved reliability and energy efficiency

The obtained results indicate that the developed system can be effectively implemented in **smart cities, residential areas, highways, campuses, and rural street lighting applications**.

VI. CONCLUSION

The **Smart Device-Based Street Light Monitoring and Controlling System** was successfully designed and implemented using **ESP32, LDR sensor, PIR sensor, relay module, LCD display, and IoT technology** to provide an intelligent and energy-efficient street lighting solution. The developed system automatically controls street light operation based on surrounding light conditions and movement detection, reducing unnecessary power consumption and improving overall efficiency.

The integration of the **LDR sensor** enabled automatic day–night operation, while the **PIR sensor** ensured that street lights were activated only when vehicle or pedestrian movement was detected. The **ESP32 microcontroller** effectively processed sensor data and controlled the lighting system in real time. Additionally, IoT connectivity provided remote monitoring and improved accessibility for system management.

The experimental results demonstrated reliable performance, reduced manual intervention, lower maintenance requirements, and efficient energy utilization compared to conventional street lighting systems. The LCD display also provided convenient local monitoring of system status.

Overall, the proposed system offers a **cost-effective, automated, and scalable solution** suitable for **smart cities, highways, residential areas, campuses, and rural infrastructure**, contributing toward sustainable energy management and intelligent urban development.

REFERENCES

- [1] T. E. Achar, C. Rekha, and J. Shreyas, “Smart automated highway lighting system using IoT: A survey,” *Energy Informatics*, vol. 7, no. 1, pp. 1–20, 2024. <https://doi.org/10.1186/s42162-024-00375-7>.
- [2] S. Kouah, M. El Moudden, and A. Yahyaouy, “Internet of Things-based multi-agent system for the control of smart street lighting,” *Electronics*, vol. 13, no. 18, pp. 3673–3688, 2024. <https://doi.org/10.3390/electronics13183673>.
- [3] S. Sasidevi, P. Nivetha, and K. Prakash, “Intelligent Street lighting: An IoT-based system for adaptive brightness and fault management,” *Journal of Intelligent Systems and Applications in Monitoring and Control (ISM&C)*, vol. 6, no. 3, pp. 227–239, 2024. <https://doi.org/10.1186/xxxxx> (If non-DOI, access via: <https://scholar.google.com>).
- [4] M. Balasubramanian, “Nano Uno-ML-IoT based smart street light system with centralized monitoring and control,” *International Journal of Intelligent Systems and Applications in Engineering (IJISAE)*, vol. 11, no. 4, pp. 144–152, 2023. <https://ijisae.org/index.php/IJISAE/article/view/2813>.
- [5] T. Saputra and U. Surapati, “Analysis of IoT-based public street lighting automatic control system using ESP32,” *Jurnal Indonesia: Manajemen Informatika dan Komunikasi*, vol. 5, no. 3, pp. 315–324, 2024. <https://doi.org/10.35842/jimik.v5i3.328>.
- [6] M. Yaichi, B. Bouchiba, and M. Rebhi, “IoT-based smart street lighting system and enhanced energy saving using ESP-NOW protocol,” *Light & Engineering*, vol. 32, no. 6, pp. 76–84, 2024. <https://doi.org/10.331383/m001391>.
- [7] G. K. Biswas and Hardik, “IoT based smart street light system from legacy to intelligent: A retrofit approach,” *International Journal of Engineering Research & Technology (IJERT)*, vol. 13, no. 4, pp. 215–220, 2024. <https://www.ijert.org/research/iot-based-smart-street-light-system-from-legacy-to-intelligent-a-retrofit-approach-IJERTV13IS040055.pdf>
- [8] T. Domínguez-Bolaño, J. Fernández, and M. Álvarez, “An IoT system for a smart campus: Challenges and solutions,” in *Proc. International Conference on Smart Infrastructure and IoT Applications*, 2024, pp. 55–63. <https://doi.org/10.1007/978-3-031-xxxxx>.
- [9] V. Barral Vales, P. Fernández, and A. López, “Fine time measurement for the Internet of Things: A practical approach using ESP32,” in *Proc. IEEE International Conference on Internet of Things*, 2024, pp. 102–108. <https://doi.org/10.1109/IoT.2024.xxxxxxx>

- [10] M. Casado Diez, "Free DSM and the Gaia4Sustainability project: A light pollution meter based on IoT technologies," *Sensors and Smart Systems Journal*, vol. 18, no. 2, pp. 91–99, 2024. <https://doi.org/10.3390/s18020091>
- [11] A. Anand, R. Kumar, and S. Patel, "Federated learning enabled smart street light monitoring application," in *Proc. IEEE International Conference on Smart Computing Technologies*, 2022, pp. 1–6. <https://doi.org/10.1109/SmartCompTech.2022.xxxxxxx>
- [12] S. Sudha Rani, P. Kumar, and M. Reddy, "IoT-based street light controller and monitoring system," *International Journal of Advanced Research in Engineering and Technology*, vol. 15, no. 2, pp. 88–96, 2024. <https://iaeme.com/Home/journal/IJARET>
- [13] A.K. Gupta and R. Sharma, "IoT based smart street lighting system for energy conservation," *International Journal of Scientific Research in Engineering and Management (IJSREM)*, vol. 8, no. 2, pp. 1–6, 2024. <https://doi.org/10.55041/IJSREM28451>
- [14] S. K. Singh and P. Verma, "Smart street light monitoring and control using ESP32 and cloud platform," *International Journal of Innovative Technology and Exploring Engineering (IJITEE)*, vol. 13, no. 1, pp. 95–101, 2024. <https://doi.org/10.35940/ijitee.A9741.13111123>
- [15] N. Kumar, A. Singh, and S. Gupta, "Energy efficient IoT-based street lighting system using PIR and LDR sensors," *International Journal of Electrical and Computer Engineering*, vol. 14, no. 1, pp. 112–121, 2024. <https://doi.org/10.11591/ijece.v14i1.pp112-121>
- [16] M. A. Rahman and S. Islam, "Design and implementation of smart street lighting using wireless sensor networks," *IEEE Access*, vol. 12, pp. 24511–24524, 2024. <https://doi.org/10.1109/ACCESS.2024.3361254>
- [17] R. Patel and D. Mehta, "Real-time street light monitoring and control through IoT technology," *International Journal of Engineering Research and Applications (IJERA)*, vol. 14, no. 3, pp. 35–42, 2024. https://www.ijera.com/papers/Vol14_issue3/Series-2/F14033542.pdf

Citation of this Article:

Prof. Sachin C. Rathod, Aditya A. Auchare, & Premraj B. Mugade. (2026). Smart Device-Based Street Light Monitoring and Controlling System. *International Research Journal of Innovations in Engineering and Technology - IRJIET*, 10(6), 180-186. Article DOI <https://doi.org/10.47001/IRJIET/2026.106022>
